



## PLANET ART. 8106

BIDET SOSPESO  
SUPPORTED BIDET  
BIDET SUSPENDU  
HÄNGE-BIDET  
BIDÉ SUSPENDIDO

50X45 CM KG 22



**Necessita:** Chiave a cricchetto reversibile 19  
**Requirement:** size 19 reversible torque wrench  
**Il faut avoir:** une clé à cliquet réversible 19  
**Bedarf:** Umschaltbarer Ratschenschlüssel 19

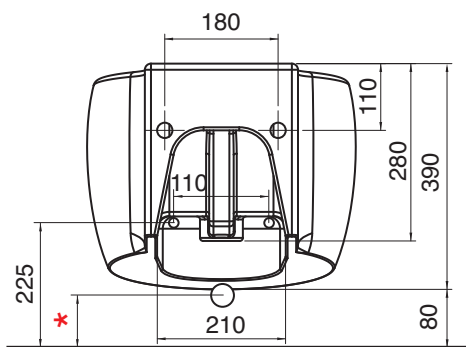
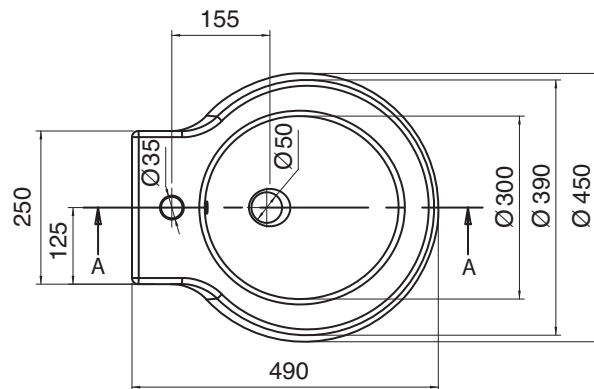

\* 65 CON/WITH: ART.10009 + ART.10011  
\* 100 CON/WITH: ART.10019 + ART.10011

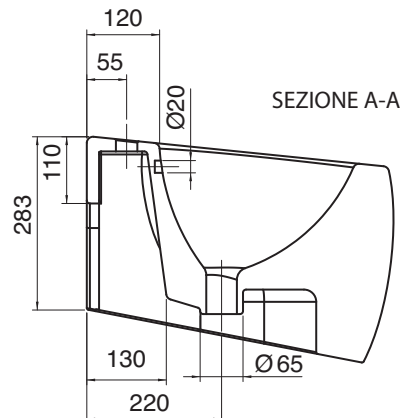

Le misure riportate sono soggette a tolleranze di +-5%  
Ci riserviamo il diritto di modificare le forme e/o le dimensioni senza alcun preavviso

The measurements indicated are subject to +-5% tolerance margins  
We reserve the right to modify the shapes and/or dimensions without prior notice

Les dimensions indiquées sont soumises à des tolérances de + ou - 5%  
Nous nous réservons le droit de modifier les formes et/ou les dimensions sans aucun préavis

Die angegebenen Maße haben eine Toleranz von +-5%  
Wir behalten uns vor, die Formen und Abmessungen ohne Ankündigung zu ändern

Las medidas indicadas están sujetas a tolerancias de +-5%  
Nos reservamos el derecho de modificar formas y/o dimensiones sin aviso previo